



Tendercare Ltd
PO Box 3091
Littlehampton
BN16 2WF
Tel 01903 726161
Fax 01903 734083
Email info@tendercareltd.com
www.tendercareltd.com

Client Name _____

Contact Name _____

Address _____

Telephone No _____

Fax No _____

E-mail _____

SWIFTY PUSHCHAIR



Complete Includes:- Foldable Lightweight Chassis with Integrated Seat Unit, Padded H Belt, Breathable Fire Retardant Upholstery, Adjustable Seat Depth, Multi-Positional back recline. Fixed Seat Tilt-in-Space 15°, Height Adjustable Footrest, Flip Up Footrest, Swivelling Front Wheels, Rear Brakes, Height Push Bar, Slot for Pommel/Abduction Block with Zip, **Shopping Basket** and Set of Tie Down Transportation Brackets fitted.

SPECIFICATIONS

Specifications	Swifty
Seat Depth	220 - 285mm
Seat Width	190 - 340mm
Back Height	620mm
Lower Leg Length	160 - 330mm
Hip Angle	90° - 115°
Foot Angle	90°
Measurement footrest (w x d)	310 x 180mm
Seat Tilt	15°
Total (w x h x d)	610 x 1020 x 980mm
Folded Measurements	610 x 380 x 730mm
Weight	12.4kg
Max Weight Capacity	35kg
Upholstery Colour	Black / Red

SWIFTY PUSHCHAIR

Please tick model required:

Note: The Swifty Pushchair has been impact tested and is suitable for use as a vehicle seat. It is supplied with the Tie Down Transportation Brackets fitted.

Swifty — Complete TH6806

Maximum Carrying Weight of Occupant and all accessories 35kg

SWIFTY® FACTORY FITTED UPGRADES

Front Locking castors (Upgrade charge)	<input type="checkbox"/> TH6238
Push Handle mounted attendant brakes - Hub (Upgrade Option) - Standard foot operated brake is removed when this option is chosen	<input type="checkbox"/> SN6259
Pneumatic Wheels(Upgrade charge)	<input type="checkbox"/> SN6239

ACCESSORIES

1/2" Sacral Pad (Fits under cover)	<input type="checkbox"/> TH9032
1" Sacral Pad (Fits under cover)	<input type="checkbox"/> TH9029
1" Side Pads (Pair)	<input type="checkbox"/> TH6834
1.5" Side Pads (Pair)	<input type="checkbox"/> TH6836
2" Side Pads (Pair)	<input type="checkbox"/> TH6835
Seat Wedge Pad *(not suitable for use with pommel)	<input type="checkbox"/> TH6314
Ramped (Anti thrust style) seat pad	<input type="checkbox"/> TH3312
Groin Adaptation Strap * (Requires H Harness or 2 point Hip Belt for fitting)	<input type="checkbox"/> TH6233
Seat Waistcoat (Small)	<input type="checkbox"/> TH6631/4
Seat Waistcoat (Medium)	<input type="checkbox"/> TH6632/4
Soft Groin Harness—Size 1	<input type="checkbox"/> TH6614/4
Heel Straps - Pair (Cam Buckles)	<input type="checkbox"/> TS6592
Toe Straps - Pair (Cam Buckles)	<input type="checkbox"/> TS6591
1" Foam Pad for Footboard (covered)	<input type="checkbox"/> TH6657
2" Foam Pad for Footboard (covered)	<input type="checkbox"/> TH6659
Frame Padding	<input type="checkbox"/> TH6622/4
Shopping Basket (Max carrying capacity 3Kg)	<input checked="" type="checkbox"/> TH6813
Playtray - Transparent	<input type="checkbox"/> TH6822
Grip Rail	<input type="checkbox"/> TH6833
Raincover—Transparent	<input type="checkbox"/> TH6638/4
Sleeping Bag - Woven Fur	<input type="checkbox"/> TH6618/4
Sun/Raincover (Hood & Leg Cover) Black Fabric	<input type="checkbox"/> TH6637/4
Sun/Raincover (Hood Only) Black Fabric **	<input type="checkbox"/> TH6637/61
Transparent Rain Shield for Sun/Raincover **	<input type="checkbox"/> TH6739
** These parts must be ordered together to form a complete rain cover	
Sun Canopy - Umbrella Type	<input type="checkbox"/> TH6594

HEADREST

TRUNK SUPPORTS

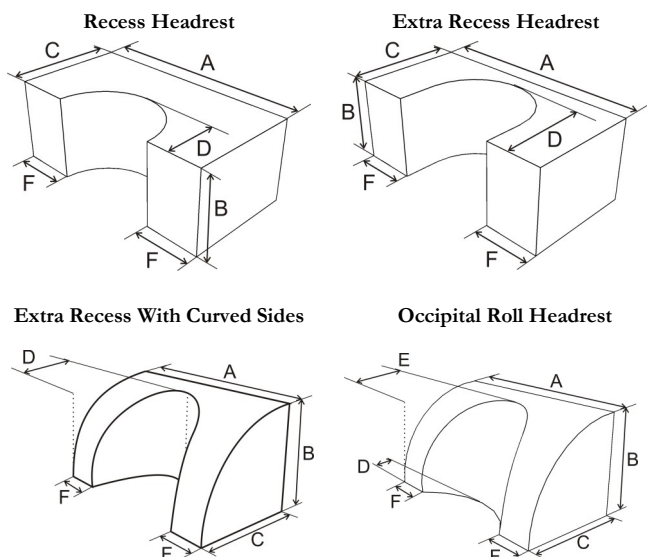

Lateral Trunk Supports

Lateral Trunk Supports with Chest Belt

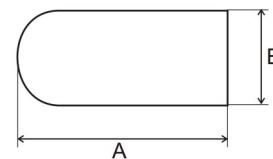
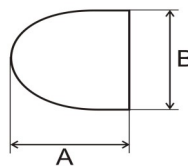

(All Dimensions in mm)	<input checked="" type="checkbox"/>	A	B
Lateral Trunk Supports (Fixed)	TH 6634/4 <input type="checkbox"/>	130	130
Lateral Trunk Supports with Chest Belt	TH 6633 <input type="checkbox"/>	220	100

(All Dimensions in mm)	<input checked="" type="checkbox"/>	A	B	C	D	E	F
Recess	TH6885 <input type="checkbox"/>	265	140	90	60	-	40
Extra Recess	TH6886 <input type="checkbox"/>	265	140	90	80	-	40
Extra Recess with curved sides	TH6888 <input type="checkbox"/>	265	140	90	80	-	40
Occipital Roll	TH6887 <input type="checkbox"/>	265	130	90	60	80	40

KINETIC BALANCE® NEOPRENE HARNESS

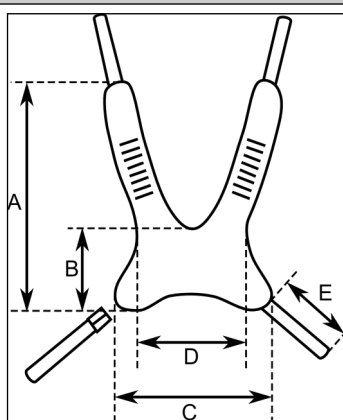

All Dimensions in mm		
<input checked="" type="checkbox"/>	Extra Small KB 5.71012.0 <input type="checkbox"/>	Small KB 5.71012.1 <input type="checkbox"/>
A	220	275
B	100	110
C	150	200
D	110	145
E	500	600

If harness to be fitted in lowest cover slots. Please tick (unless indicated harness will come fitted in middle slots)

POMMEL

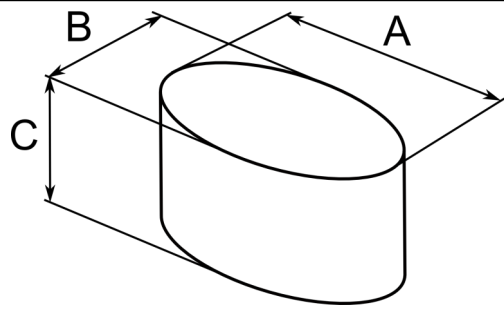

(All Dimensions in mm)	<input checked="" type="checkbox"/>	A	B	C
Pommel (Size 1) TH 6620/4	<input type="checkbox"/>	100	60	90

THOMAS HILFEN® (OLD STYLE) NEOPRENE HARNESS

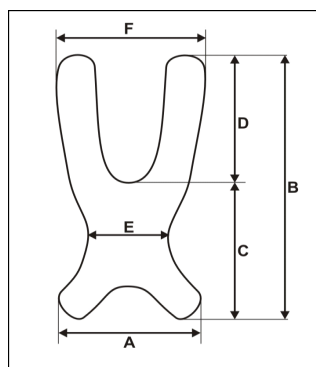

<input checked="" type="checkbox"/>	Small TH6385 <input type="checkbox"/>
A	125
B	210
C	105
D	90
E	55
F	225

PELVIC STRAPS

- Centre Pull 2 pt hip belt (metal push button) Extra Small *Bodypoint*® BES11612
- Centre Pull 4 pt hip belt (metal push button) Extra Small *Bodypoint*® BES13241

KINETIC BALANCE ANKLE POSITIONING CUFFS - Velcro Fastening

<input checked="" type="checkbox"/>	Size	A (ankle circumference)
<input type="checkbox"/> KB8.70001.0	Extra Small	180mm<
<input type="checkbox"/> KB8.70001.1	Small	180mm < 220mm
<input type="checkbox"/> KB8.70001.2	Medium	220mm < 260mm
<input type="checkbox"/> KB8.70001.3	Large	>260mm



